



NOTA 142

USER GUIDE



TABLE OF CONTENTS

INTRODUCTION.....	4
Welcome	4
NOTA 142: The Ultra Compact PoE Amplifier	4
Features Summary	5
OVERVIEW.....	7
Nota’s Layout.....	7
Signal Flow.....	8
INSTALLATION.....	11
Unboxing.....	11
Mounting.....	11
Wiring.....	14
CONFIGURATION.....	16
Configuring Nota with ArmoniaPlus System Design Software	16
Network Setup	16
AES67.....	17
Loudspeakers Preset.....	19
Loudspeakers Diagnostic	19
APIs and Third-Party Plugins	20
Cloud Monitoring	20
OPERATION.....	21
Local Interface.....	21
Software Control.....	22
MAINTENANCE.....	24
Updating firmware	24
APPENDIX.....	26
Third-Party Plugins (Q-SYS)	26
UI - LED behavior and operation	27

INTRODUCTION

Welcome

Thank you for choosing Powersoft Nota amplifier

The **Nota Amplifier** represents Powersoft’s latest innovation in ultra-compact PoE amplification for networked AoIP applications, particularly where space and wiring constraints pose challenges. Thanks to its modular design, flexibility, and small form factor, the amplifier integrates seamlessly into both existing systems and future expansions. Its straightforward installation procedure makes it an ideal choice for AV and IT professionals seeking versatility, efficiency, and swift deployment.

This document provides comprehensive installation instructions, details the key features and configuration methods, and offers guidelines for the operation and maintenance of the Nota amplifier. While the content herein is intended to support professionals across all stages—design, installation, configuration, operation, and maintenance—please note that it does not cover every possible application or scenario. For further inquiries or assistance, contact your Powersoft local dealer or a specialized technical support representative.

NOTA 142: The Ultra Compact PoE Amplifier

The Nota 142 is an advanced and versatile amplifier, delivering a remarkable level of performance relative to its compact size. Outfitted with 2 output channels, it supports routing of networked and USB digital inputs, along with onboard signal processing capabilities and an extensive feature set. This design ensures consistent, high-quality audio reproduction across a wide range of use cases.

Its compact form factor and **PoE/PoE+** input (supplied through the RJ45 port) eliminate the need for a separate power cable while ensuring reliable data communication. Combined, these qualities make Nota 142 ideal for scenarios requiring network-ready solutions with minimal wiring and maximum efficiency. In total, the amplifier can deliver up to 140 W of output power, distributed flexibly across the two channels thanks to its power sharing capability.

Designed with modularity and scalability in mind, the Nota amplifier offers a practical and straightforward solution for:

- **Standard Ecosystem Integration** Incorporation into a typical Powersoft ecosystem, leveraging existing workflows and compatibility.
- **Mixed-System Environments** Enables interoperability in more complex networks (e.g., Dante-compatible systems through AES67). This may require specialized patching in ArmoníaPlus (or any other control user interface) to accommodate devices from various manufacturers.

Whether delivering background music, powering haptic transducers, or driving full-range speakers in conference rooms and hospitality venues, Nota stands out for its efficiency, scalability, and future-proof audio capabilities.

Its minimal footprint suits installations where space is at a premium, while its power-sharing capabilities and PoE design allow integrators to deploy advanced audio solutions in a wide range of environments.

The tables below summarize the core attributes of the Nota Amplifier and highlight why it excels in demanding installations requiring a compact, efficient, and network-ready audio solution.

Inputs	Outputs	Total Rated Power @ 4 Ω	Networking
2x AES67 2x USB	2	140 W	AES67

Table 1 – Inputs outputs availability

Power Source	PoE+	PoE
@16 Ω symmetrical*	35 W	30 W
@8 Ω symmetrical*	50 W	35 W
@4 Ω symmetrical*	70 W	50 W
@2 Ω symmetrical*	50 W	35 W
@16 Ω asymmetrical**	40 W	35 W
@8 Ω asymmetrical**	70 W	50 W
@4 Ω asymmetrical**	110 W	75 W
@2 Ω asymmetrical**	80 W	55 W

Table 2- Maximum output power per channel depending on the supplied power source (PoE/PoE+)

*: All channels driven

** : Maximum power-sharing capacity per channel

Features Summary

Compact & Space-Saving Design

Featuring an exceptionally small form factor, the Nota amplifier is well suited for installations where space is at a premium. Its streamlined dimensions ensure easy integration into tight environments, while still delivering consistent and reliable performance.

Optimized Performance

Despite its compact size, the Nota amplifier provides up to 140 W of total power across two channels. This output capacity ensures excellent audio fidelity in a range of applications and leverages power sharing to allocate the necessary wattage to each channel.

PoE/PoE+ Integration

The Nota amplifier seamlessly incorporates PoE/PoE+ technology, allowing both power and data signals to travel over a single Ethernet cable. This design greatly simplifies installation and reduces the need for complex wiring, thereby lowering overall deployment costs.

Default Auto Setup

At powerup integrated auto-setup feature automatically measures the impedance curve of connected speakers, applying limiters and a high-pass filter to safeguard system performance.

On Demand Auto Setup (available from further FW release)

Advanced Dynamic EQ processing to enhance sound quality while preventing excessive low-frequency energy from damaging the speakers will be applied at pushbutton press

The auto-setup features can be applied only if the product doesn't have any preset preloaded on it.

Onboard DSP

A built-in DSP engine enables precise audio management and system optimization. Through this onboard processing, users gain access to speaker health monitoring, EQ adjustments, and other audio controls necessary for fine-tuning overall performance.

Control Options

The Nota amplifier supports configuration through **ArmoníaPlus** software and is compatible with third-party applications via available APIs. This flexibility allows for intuitive remote management, enabling AV and IT professionals to easily adapt system settings to specific requirements.

USB Connectivity

Equipped with a USB Type-C port, the amplifier offers a convenient means of integrating external multimedia devices, enabling quick and convenient integration with laptops and similar sources. This port also operates as

a USB-to-AES67 converter for networked audio transmission, providing additional configuration options and enhancing overall system flexibility. Moreover, the amount of power provided by the USB port gives the possibility to test, control and configure the amplifier in the UI, and to transmit audio signals over the network when no PoE is available.

**see wiring chapter for appropriate setup*

AES67 Support

Native support for the AES67 standard allows the Nota amplifier to integrate effortlessly into Audio-over-IP (AoIP) networks. By maintaining high-quality audio streaming, users can confidently deploy the amplifier in environments that demand reliable and scalable AoIP solutions.

Cloud

When combined with the **Verso Gateway**, the Nota amplifier supports real-time monitoring via **MyUniverso**. This cloud-based platform delivers remote diagnostics and control capabilities, enabling professionals to oversee system health and performance from any location.

OVERVIEW

Nota's Layout

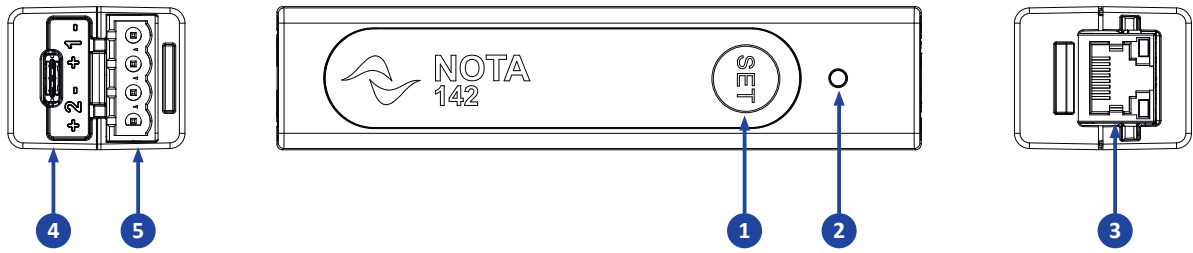

Figure 1 – Nota's layout

1. Push-button for on Demand Auto Setup*, reset operations (network and factory reset) and call to the software.
2. RGB LED for visual indication on the operational status of the amplifier. Different colors and blinking patterns provide information about power status, signal limiting, and operational alerts.
3. Ethernet RJ45 connector for control, AES67 network connectivity and PoE.
4. USB Type-C port, media player functionality, optional connection for programming/debugging.
5. Output channels

**available from FW version 1.1.0 onwards*

Signal Flow

Nota signal flow is built as highlighted in the figure below.

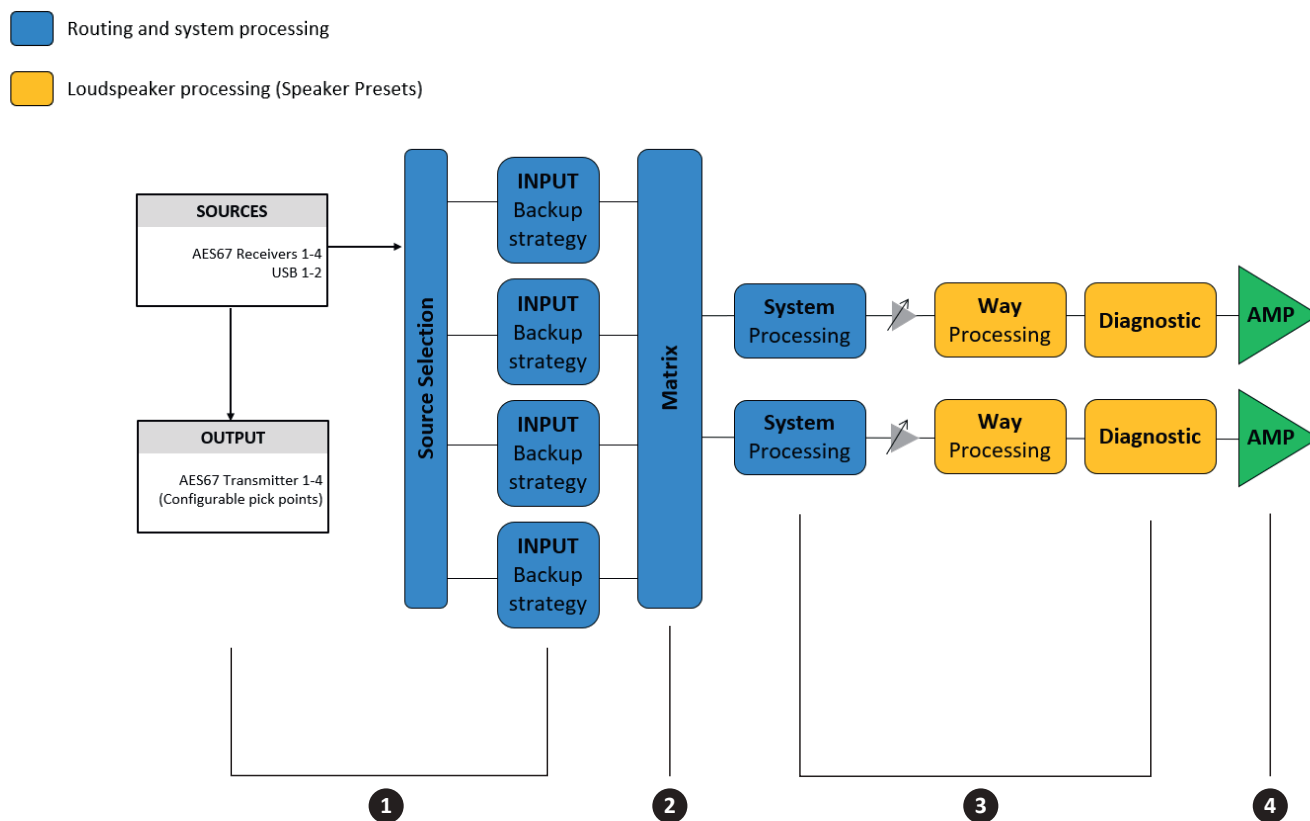

Figure 2- Signal flow schematic for Nota 142

1 Inputs

Nota amplifier features four input modules, two for networked sources, and two for USB sources. All sources are input modules allowing configuring up to four priority sources per each matrix input. The backup strategy functionality allows automatic switchover of USB or AES67 inputs in case of failure according to two different strategies, Signal Presence or Pilot Tone, described afterwards.

Signal Presence

By default, When the amplifier is configured for backup strategy based on signal presence, the amplifier automatically plays the next-priority source in case the higher-priority source stop playing. The typical application is that of an USB or AES67 source set in the first position of the priority queue, with its backup content set in the second position. In the event of failure of the first priority source, the amplifier play the second priority source automatically as soon as signal presence on the first priority source is not detected.

Pilot Tone

When configured for backup strategy based on pilot tone, the amplifier automatically play the higher-priority input that shows a pilot tone at a given frequency and level settings. The typical application is that of a digital input configured to play announcements (embedding a pilot tone) with a higher priority compared to other sources, in this case the amplifier play the announcement input as soon as the pilot tone is detected, and switches back to the lower-priority input when the announcement finishes. The input pilot tone detection can also be used to trigger alarms in case the pilot tone is not present on the connected sources, allowing monitoring the signal distribution infrastructure (network infrastructure).

It is possible to disable the input backup strategy by setting it to **Manual (Force)**. This will ensure that the amplifier will always play the configured source.

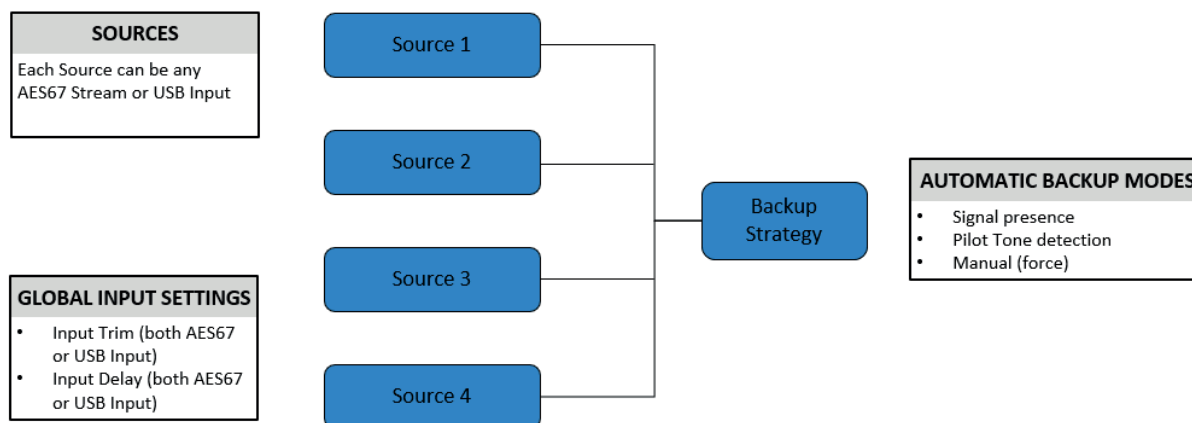

Figure 3- Input and backup strategy architecture for USB and AES67 sources

The matrix input channels match the source selection results. As per default, IN1 will be the first selected AES67 source, IN2 the second selected AES67 source, IN3 the first USB input and IN4 the second USB input.

	1 st	2 nd	3 rd	4 th
Matrix Input Ch 1	AES67 1	AES67 3	None	None
Matrix Input Ch 2	AES67 2	AES67 4	None	None
Matrix Input Ch 3	USB 1	None	None	None
Matrix Input Ch 4	USB 2	None	None	None

Table 3- Matrix input channels with their priorities

Although, the matrix input channels can be modified at any time via software.

2 Matrix

The matrix connects the inputs to the loudspeakers. Nota's matrix supports up to 4 inputs x 2 outputs. Each matrix tap provides continuous gain control from 0dB to -inf., allowing simple routing as well as mixing two or more inputs. By default, the matrix is configured as follows: IN1 + IN3 to OUT1, IN2 + IN4 to OUT2, where the summed inputs corresponds to the mixing of that inputs. This default setup allows any signal source (whether AES67 or USB) to be routed automatically without requiring prior matrix configuration. However, the internal matrix can be changed at any time via software.

3 Output processing

Each amplifier output provides both loudspeaker and system-level processing.

The loudspeaker processing includes extensive EQ and limiting capabilities, making Nota amplifier suitable to accurately drive and monitor the status of any modern loudspeaker, while ensuring compatibility with Powersoft's extensive Speaker Preset library. The system processing allow for complex system tuning via ArmoníaPlus software.

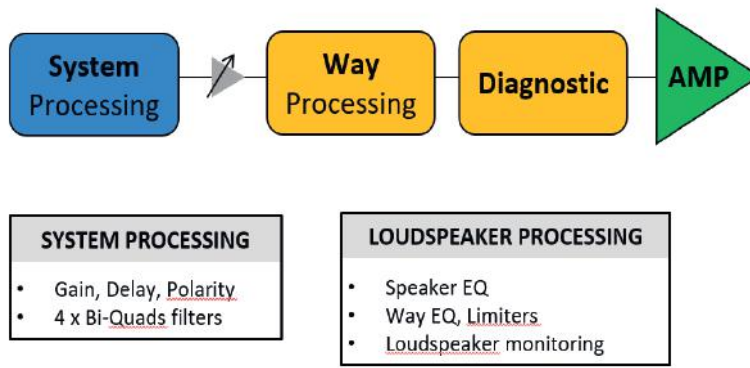

Figure 4- Output processing architecture

4 Amplifier outputs

Nota amplifier is designed to deliver pristine sound with significant sound pressure levels in relation to its sizes. Indeed, each channel output can deliver up to nearly all of the amplifier's available power when asymmetrically loaded (up to 110 W ref. @ 4 Ω) and can drive low impedance loudspeakers from 16 to 2 Ω without the need for configuration. Besides, output channels feature loudspeaker diagnostic tool for easy troubleshooting. For more details on the available tools, see the Loudspeaker Diagnostic section of this manual.

INSTALLATION

Unboxing

Nota amplifier has been completely tested and inspected before leaving the factory. Carefully inspect the shipping package before opening it, and then immediately inspect your new product. If you find any damage, immediately notify the reseller.

The package contains:

- 1x Nota amplifier
- 1x Safety Warning and Regulations sheet
- 1 x Assembly instruction
- 1x Euroblock output mating connector
- 1x Support add-on
- 4x Black cable ties 2,5mm
- 1x QR code linking to the online user guide

Mounting

When installing the Nota amplifier, it is recommended to use the support add-on provided in the package. This additional component secures the mounting and increases airflow, thereby improving amplifier cooling. To mount the amplifier on its support, first slide it onto the bracket on the correct side, following the indicated arrow as illustrated in Step 1 of Figure 5. Next, engage the opposite side in the direction shown in Step 2. Step 3 illustrates the disassembly procedure, which can be carried out with the aid of a screwdriver.



Figure 5 – Mounting on support add-on

For enhanced stability, two of the supplied cable ties can be threaded through the support as indicated in Figure 6. Insert the cable ties through the side openings of the support as indicated by arrows in Step 1, completing this action before snapping the amplifier into position on the support (Figure 5, Steps 1 and 2). Once the amplifier is anchored, loop the cable ties around the unit and draw them through the matching holes on the opposite side (Step 2). Tighten the ties in the direction shown in Step 3, then trim any excess length.



Figure 6 – Cable ties secure attachment amplifier-support

Several mounting options are available for Nota amplifier, each leveraging the design features of the support:

1. Screw Mounting

Ideal for horizontal or vertical planar surface placement. Place the support component on the chosen surface and align it with the prepared holes. Proceed by inserting two screws through the corresponding holes at the base of the support, as illustrated in Figure 6, and tightening them securely. Use screws that are at least 13 mm long with a maximum shank diameter of 5 mm; the screw head should not exceed 9 mm in diameter and 4 mm in height. Once the support is firmly attached, position the amplifier and slide it into the support (following step 1 and 2 of Figure 5) until it is fully seated.

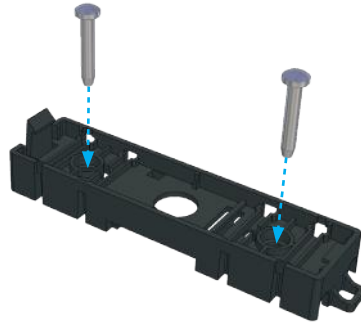

Figure 7 – Surface mounting with screws

2. Pole Mounting

Once the amplifier has been attached to its support, fasten it to a pole using the provided cable ties, ensuring the output connectors face upward. Follow the instruction steps given in Figure 8 for proper assembly. Two cable ties should be inserted into the corresponding side holes (Steps 1 and 2), passed completely around the pole and tightened (Step 3). Once the unit is securely fastened, any excess tie length should be trimmed.

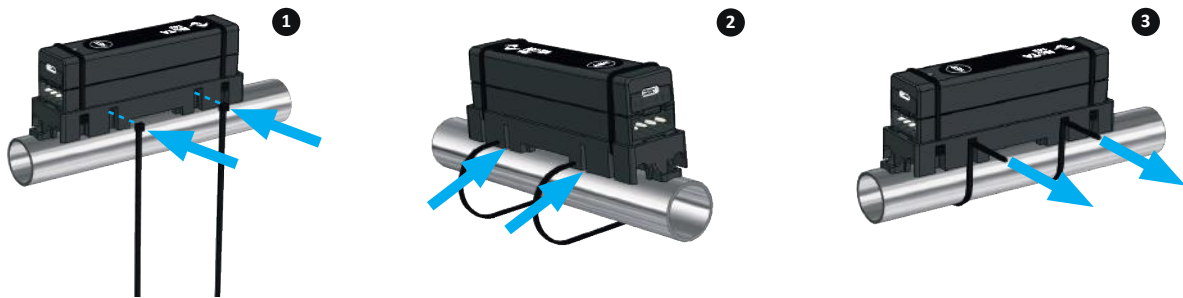

Figure 8 – Pole mounting with cable ties

3. Snap-on DIN rail

The support is sized to fit DIN rails, allowing the amplifier to be quickly snapped onto a rack bracket or similar mounting structure. Follow the steps given in Figure 9 to securely attach the support add-on on a DIN rail. Position the support on the DIN rail from the correct side as shown in Step 1, sliding it in the direction of the arrow, then secure the opposite side by pressing it onto the rail until an audible click confirms engagement (Step 2). Complete the installation by snapping the amplifier into position on the support as illustrated in Steps 1 and 2 of Figure 5. Step 3 illustrates how to remove the support from the rail with the aid of a screwdriver.

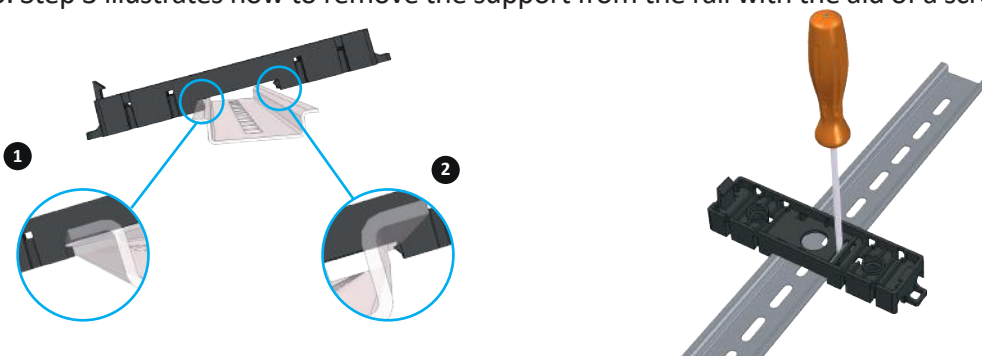

Figure 9 – Mounting on DIN rail

4. Hanging Mounting

The support includes two additional holes at the two ends, allowing the amplifier to be hung from an external fixture. These holes are intended solely for hanging the unit and should not be used with screws. Once the hanger is in place, insert the amplifier into the support following the procedure shown in Figure 5 and 6.



Figure 10 - Hanging Mounting

Nota's numerous mounting options offer exceptional flexibility for a wide range of installation scenario. Regardless of the chosen method, ensure the amplifier is kept away from heat sources and installed in a well-ventilated environment to maintain optimal performance.

The mechanical drawing below illustrates the amplifier's dimensions in millimeters.

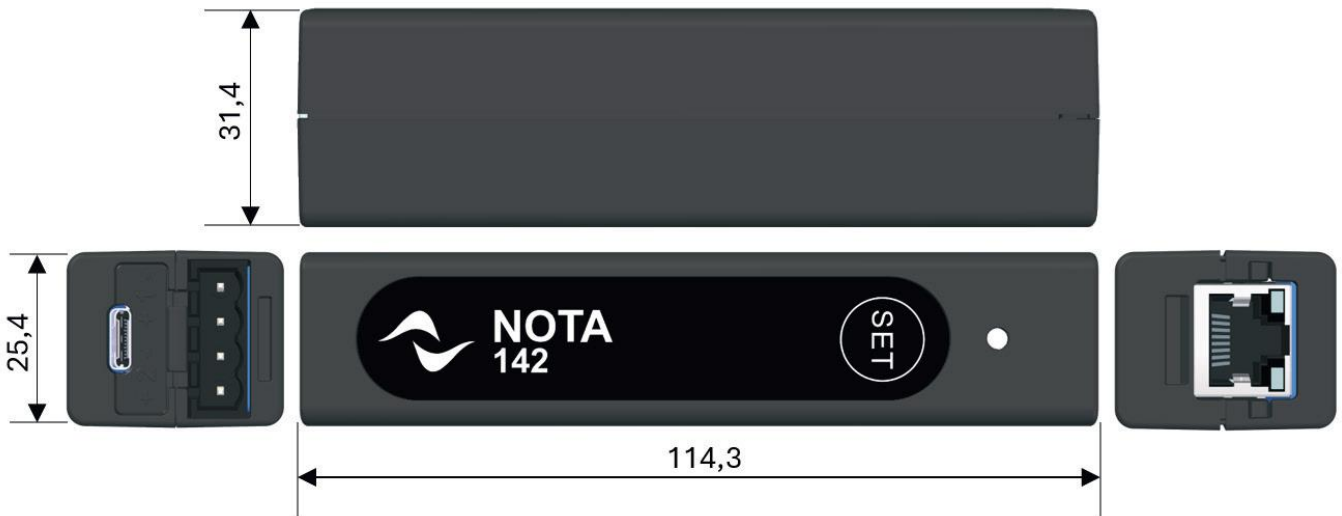

Wiring

This section provides the pin-out specifications and shows the appropriate cabling for Nota amplifier.

Input

Nota amplifier features digital input connections:

1x RJ45 ETH port for AES67 inputs

1x USB Type-C for further digital inputs

Please note: To take advantage of the audio input via the USB port, the transmitter device must first be connected to Nota using a USB cable, and only subsequently should the RJ45 connector be plugged in.

Output

The output connector is Phoenix MSTBA 2,5/ 4-G-5,08 BK.

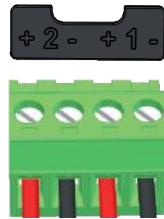

Mains (PoE)

The primary power supply for Nota amplifier is given by PoE/PoE+ through Ethernet cable on RJ45 Ethernet port.



Network

1x100 Mbit/s Ethernet, RJ45 socket with yellow-green diagnostic LEDs of the type Phoenix 1149873. The port is configured as SWITCHED with control+AES67.

After the appropriate cables for the amplifier's ports have been acquired, the system wiring can be completed. If all cables enter centrally— for instance, through a wall opening that aligns with the rear aperture of the support— they should pass through the support's central passage and directed toward the side corresponding to the appropriate ports (see Figure 11). When cables approach from opposite directions, it is preferable to guide them along the external cable guide of the support, as shown in Figure 12, to reduce strain and minimize the risk of accidental disconnection.

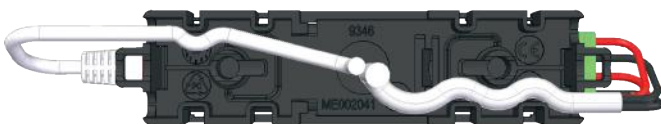

Figure 11 – Wiring from the center

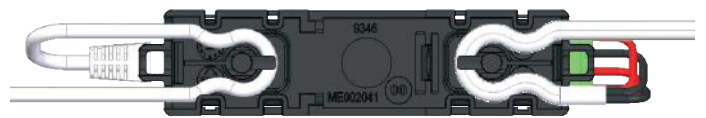

Figure 12 – Wirings from opposite sides

Once all required connections and wiring are in place, Nota is ready for operation.



CONFIGURATION

This section outlines the available configuration methods for Nota amplifier and details the steps required to properly set up the amplifier.

Nota parameters can be configured using ArmoníaPlus software, ensuring that the system operates correctly and efficiently.

Configuring Nota with ArmoníaPlus System Design Software

ArmoníaPlus System Design Software is a powerful yet intuitive software for configuring, controlling and monitoring Powersoft products. With ArmoníaPlus, users can set up their audio system quickly and easily, from the installation of the products to the configuration of their parameters. The ArmoníaPlus software can be downloaded from the Powersoft website.

To configure Nota amplifiers with ArmoníaPlus System Design software, the amplifier must be connected to the same network as the PC running the software.

Once the network connection is established, the amplifier can be connected to the software via the **Match** procedure in two ways:

1. Open the **Design → Match** screen on ArmoníaPlus and click the **Discovery** button in the top right corner. The amplifier should appear in the list of online devices. To control the amplifier, drag it onto the workspace or click the **Add All** button in the top right corner of the screen.
2. Open the **Design → Add** screen on ArmoníaPlus and click on **Amplifier**, in the top left corner. From here, navigate the devices library by clicking on **Powersoft → Opera Series**. Select the correct amplifier model from the list and click **Add & Close**. Now go to the **Design → Match** screen on ArmoníaPlus and click **Discovery**. The real amplifier will show up in the list of online devices. From here it is possible to:
 - a. Drag and drop the discovered amplifier to its virtual counterpart on the workspace.
 - b. Click on the virtual amplifier icon on the workspace, and then press the SET button on the front panel of the amplifier. This will complete the match operation automatically, allowing the amplifier to be remotely controlled.

Through the match operation, ArmoníaPlus will be able to access and control all device parameters, including DSP settings, AoIP input patch and output settings. For more information on matching virtual and physical devices, as well as other ArmoníaPlus tutorials, please visit our YouTube channel.

Network Setup

Nota is equipped with one Ethernet port, which operates in **Switched** mode. This configuration supports both control and AES67 over one single port. By default, the amplifier's unique IP address for both Control and AES67 is obtained via DHCP addressing mode.

Network setup can be changed via software accessing the device details or from the workspace.

To configure the network settings of Nota amplifiers via ArmoníaPlus, access the **Device details** page by selecting the cursor option in **Workspace** view and double click the device. From the left-hand panel, select **Options** and then **Network**.

As per default, DHCP is chosen. In this mode the system automatically obtains an IP address from the DHCP server on the network. When Static is chosen, the user can manually enter the IP address, subnet mask, and gateway.

It is possible to retrieve the network's default configuration via the Network configuration panel in ArmoníaPlus or by performing a network reset. For details on how to complete a network reset using the frontal button, refer to the Operation section of this User Guide.

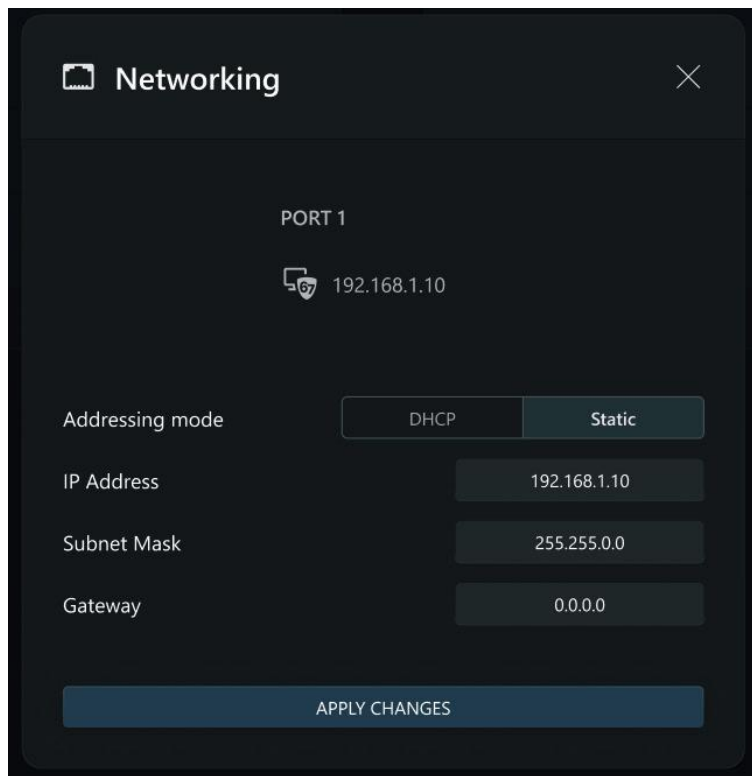

Figure 13- Network setup panel

AES67

AES67 is a technical standard for network-based audio applications, enabling high-performance Audio-over-IP (AoIP) interoperability among different network systems.

Nota amplifier supports AoIP through the AES67 protocol, providing real-time configuration, control, and audio streaming over the network. It is capable of receiving two AES67 flows, each able to accommodate up to four potential AES67 sources, with two of those sources designated as backup content for source selection. Source selection and input patching can be managed via ArmoníaPlus software or through a web-based interface.

For specific instructions on patching AES67 inputs to Nota amplifier in ArmoníaPlus, refer to the Operation section of this manual.

AES67 Inputs

The Nota amplifier offers four AES67 inputs organized into two AES67 flows. These inputs can be patched to AES67 audio sources residing on the same network, facilitating seamless audio streaming. Patching is handled in the input configuration section, accessible via both the amplifier's AES67 configuration web page and Powersoft ArmoníaPlus software. Users may freely assign the amplifier's networked audio inputs to any AES67 source in its network, thereby enabling reliable, high-quality audio streaming.

AES67 Outputs

Nota amplifier can be configured to transmit four AES67 channels for various purposes, including USB-to-AES67 conversion or distributing networked signals to other amplifiers or loudspeakers. By leveraging the amplifier's built-in loudspeaker and system processing, digital audio can be sent over the AES67 network via one or more of the following pick-points:

Physical inputs, such as any of the AES67 or USB input channels

Matrix inputs, such as any of the post-source selection matrix inputs

Matrix outputs, such as any of the matrix outputs

Ways out, such as any of the post-processing amplifier outputs.

By default, no pick-points are selected, meaning that no AES67 streams are transmitted. Users can select pick-points via Powersoft ArmoníaPlus in the AES67 settings or through the third-party API, enabling flexible routing of outgoing audio streams.

This flexibility enables the amplifier to seamlessly integrate with existing network infrastructures, accommodating both straightforward and advanced multicast setups.

Configuring AES67 via Powersoft ArmoníaPlus software

Within ArmoníaPlus, the AES67 settings are located under the **Options** section of the **Device details** page. From this interface, it is possible to:

- Edit the AES67 device name
- Set latency of 2, 4, 5, 6 or 10 milliseconds
- Configure PTP domain and priorities
- Choose the transmitted channels

The sample rate is fixed at 48 kHz.

Choose a higher latency value if your network bandwidth is limited or you need to ensure greater stability. This helps avoid audio dropouts and clock synchronization issues.

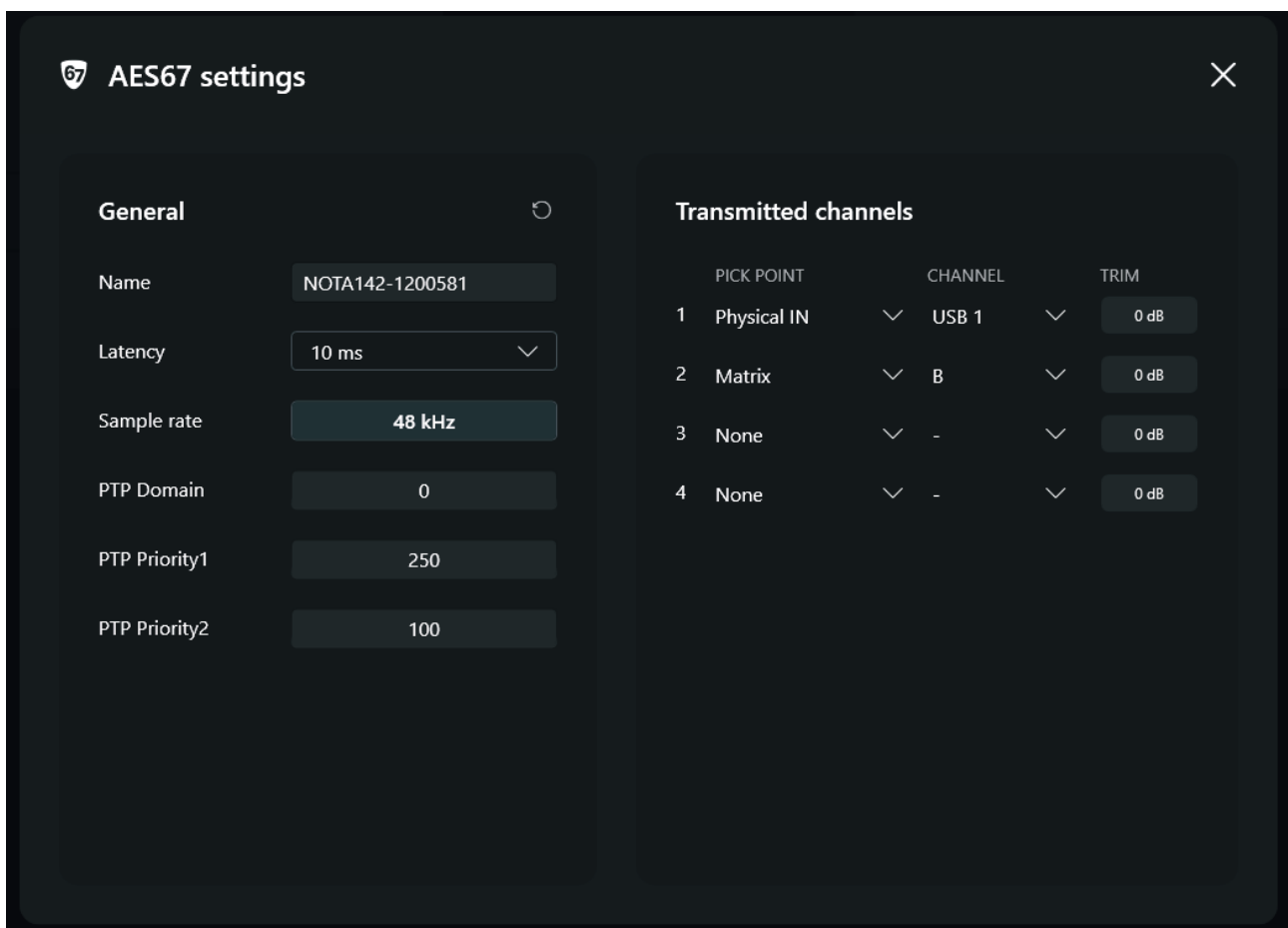

Figure 14- AES67 settings panel on ArmoníaPlus

Configuring Network and AES67 via web page

Network and AES67 settings can also be managed through a web interface, which provides the same configuration options found in ArmoníaPlus. These include IP addressing, AES67 device name, latency, and PTP settings. In addition, AES67 input patching is available from this window.

To access the amplifier's web interface, enter the AoIP port's unique IP address into your web browser.

The screenshot shows the 'AES67 Config' web interface for device 'NOTA142 | 1200581'. It is divided into three main sections: General Settings, PTP Settings, and Input Patching, followed by an Output Configuration section.

General Settings

- Device Name: NOTA142-1200581
- Latency: 10 ms
- Sample Rate: 48000 Hz
- Addressing Mode: DHCP (selected), Static
- IP address: 192.168.1.60
- Subnet mask: 255.255.255.0
- Gateway: 192.168.1.253

PTP Settings

- Priority 1: 250
- Priority 2: 100
- Domain: 0

Input Patching

- Four input channels, each currently set to '-' with a trash icon to the right.

Output Configuration

- Multicast addressing mode: Auto (selected), Manual
- Multicast address: 239.4.191.86

A 'Save' button is located at the bottom right of the PTP Settings section.

Figure 15- Network and AES67 settings panel on web interface

Loudspeakers Preset

Nota amplifier comes with a library of loudspeaker presets that can be accessed through ArmoníaPlus System Design software. These presets are designed to provide optimized performance for a range of loudspeaker models, making it easier for users to quickly set up the system. The presets parameters typically include loudspeaker type, EQ, Crossovers, and protection Limiters.

In addition to the loudspeaker presets distributed via ArmoníaPlus software, users can also create their own custom presets. This can be done by accessing the amplifier's internal DSP properties in ArmoníaPlus and then selecting the **Speaker Configuration** icon. For more information on how to load and create loudspeaker presets, please visit our website or Youtube channel.

Loudspeakers Diagnostic

Nota amplifier is equipped with a module of diagnostic tool to help users monitor the health of connected loudspeakers. To access the diagnostic tool, select the device in the Workspace menu in ArmoníaPlus software, double-click it to open the device menu, and then select **Ways → Diagnostic**. From there, it is possible to configure the pilot tone generator and enable/disable alarm:

- Pilot Tone Load Monitor** This tool allows the users to configure each output to generate a pilot tone of a specific frequency and level. This pilot tone can be used to monitor the status of distributed loudspeaker systems. If the impedance measured at the pilot tone frequency is outside of the range specified by the user, alarm notifications will be triggered. This alarm is indicated in Health+ and will be available in Powersoft's API for third-party monitoring of amplifiers.

APIs and Third-Party Plugins

Nota amplifier provides APIs and third-party plugins for developers willing to fully control all aspects of the device. The APIs provide an interface for comprehensive device status information and control features for standard users, as is done in ArmoníaPlus.

The available APIs for Nota amplifier are:

- Advanced protocol
- SNMP protocol

The advanced protocol is a comprehensive 3rd party protocol PBusX, an UDP based proprietary protocol of Powersoft, which allows users to control and monitor nearly all aspects of the amplifier, including DSP settings, AoIP input patch and output settings, and more. The Nota amplifier is also compatible with SNMP protocol, allowing for monitoring status of the amplifier from a remote location. Via SNMP, it is possible to monitor

- Any hardware fault of the device
- Temperature status (normal, high temperature, over temperature)
- Any output-related fault: hardware, short-circuit and pilot tone alarm engaged
- Any input-related fault: input clip, no input detected on the pilot tone backup strategy

Powersoft not only provides APIs but also builds and maintains ready-to-use plugins for the most popular third-party system processors. For additional information on the third-party plugins or for the API control protocols for Nota amplifier, please consult the technical documentation available on Powersoft's website or contact the Powersoft support team for further assistance.

Cloud Monitoring

The Nota amplifier integrates with **Powersoft's** cloud monitoring platform, providing remote access and real-time oversight of amplifier performance. Users can also configure email notifications to receive alerts when specific events occur.

To connect the amplifier to the **Powersoft Cloud**, begin by creating a project in ArmoníaPlus and adding the Nota amplifier to your workspace. Ensure the amplifier is connected to your local network and configure the project for cloud monitoring. The connection between Nota amplifier and myUniverso platform relies on the **Verso** gateway. Connect Verso to both the local amplifier network and the internet to establish communication with the Universo cloud platform. Refer to the Verso manual for detailed instructions on setting up Verso with your system. Additional information is available in the **Powersoft Cloud User Guide** or on the **Powersoft website**.

Once the amplifier is connected to the Powersoft Cloud, it is possible to configure email notifications for various events, including changes in power state, alarms, output channel status, and updates to information like model, serial number, and firmware version. These notifications allow users to remotely monitor and troubleshoot the amplifiers from any location, making Powersoft Cloud an invaluable tool for efficient system management and maintenance.

OPERATION

Nota amplifier does not include a dedicated power on/off switch. In order to power the amplifier, it must be connected to a PoE injector or a network switch that supports PoE. This arrangement ensures power, AoIP data exchange and control are carried through a single cable.

Local Interface

The only functions accessible directly from the amplifier's panel without software control, are Auto Setup, Reset operations, and Pairing with software. Each of these actions is performed using the **SET** button located on the amplifier's frontal. During these operations, a LED provides visual feedback by changing color, turning on or off, or blinking in specific patterns.

On demand Auto Setup (Available from FW 1.1.0 onwards)

The Auto Setup procedure measures the impedance curve of connected speakers, applying a high-pass filter to safeguard system performance. It will also apply a Dynamic EQ processing to enhance sound quality while preventing excessive low-frequency energy from damaging the speakers.

The auto-setup features can be applied only if the product doesn't have any preset preloaded on it.

The following steps outline how to perform the Auto Setup procedure on the amplifier:

1. Press the button for more than one second, causing the LED to turn off.
2. After 3 seconds, the LED becomes steady purple, indicating that the amplifier is ready to begin autoseup.
3. If the button is released within the next 3 seconds, the autoseup procedure initiates. During this phase, the LED blinks purple.
4. Once the operation is complete the LED reverts to its previous state, and the amplifier resumes normal operation.
5. If the button is held for more than 6 seconds, the LED turns off and Auto Setup procedure is canceled.

Factory Reset

A factory reset can only be performed during a cold start, which occurs when the device has been fully disconnected from power and then powered on again. In this state, all volatile memory is cleared, preventing accidental resets during normal operation. At power-up, the LED color corresponds to the device's status at that moment (e.g., green for normal operation, red for an alarm condition). A factory reset returns the amplifier to its original, default settings.

To perform the reset:

1. Ensure all power sources are disconnected from the amplifier, making sure the device is fully powered down
2. Reconnect power to the amplifier. During this initial startup, the amplifier is in a "cold start" state, which allows a factory reset to occur.
3. While powering up, press and hold the button for 3 seconds. After 2 seconds LED turns off and then illuminates white, indicating that the reset procedure can be initiated.
4. Release the button within the specified time frame (e.g., within 3 seconds of the LED turning white) to confirm the factory reset; if the button is held too long (beyond 6 seconds), the reset is canceled.
5. Once the procedure is successful, the LED will blink white, then returns to its default state, indicating that the amplifier has been restored to factory settings.

Important: Performing a factory reset erases all custom configuration settings. The amplifier will need to be reconfigured via software afterward to ensure proper system operation.

Network Reset

The network reset process reverts the amplifier's network settings to their default DHCP configuration. To perform a network reset:

1. Press and hold the button for 7 seconds.
2. After 7 seconds, the LED turns steady cyan.
3. Release the button within the next 3 seconds. The LED then blinks cyan, indicating the network has been reset to DHCP mode.
4. If the button is held beyond 10 seconds, the operation is canceled. When the button is ultimately released, the LED reverts to its previous state, leaving the existing network settings unchanged.

Pairing with software

A short press of less than 1 second activates a callback command for both ArmoníaPlus and any third-party API. Conversely, the software or API can send a call command to the amplifier.

1. When initiated by software (or a third-party API), the LED blinks white to indicate a call is in progress.
2. In ArmoníaPlus, the LED continues blinking for as long as the amplifier is selected. Once deselected, the blinking ceases.

Software Control

Nota amplifier channels can be configured via software. Simply connect your device to the same network of your PC and open ArmoníaPlus.

Once the software is opened, it is possible to patch amplifier inputs.

Note: Be sure to synchronize ArmoníaPlus with your amplifiers before starting the patching operation. Patching operation cannot be performed on offline devices.

Source patching can be performed in two different ways in ArmoníaPlus: from the **Workspace** or from **Device details**.

From the **Workspace**, open the **Config** tab and select the **Input** function. From here it is possible to assign a connected source to each amplifier input channel. Select a channel on the virtual Nota and patch the AES67 or USB source. To patch a single source to multiple input channels simultaneously, select multiple channels on the virtual Nota and patch them in one step.



Figure 16- Input patching panel on ArmoníaPlus

Alternatively, input patching can also be conducted from the **Device details** page.

From **Workspace** select **cursor** and click on the amplifier you wish to configure. This will open the **Device details** page. Navigate to the **Source Selection** section and assign each channel to the desired source by clicking on the arrow on the corresponding input priority block. This will open a menu from which it is possible to choose the source to assign for each amplifier's input, as illustrated in the figure below.

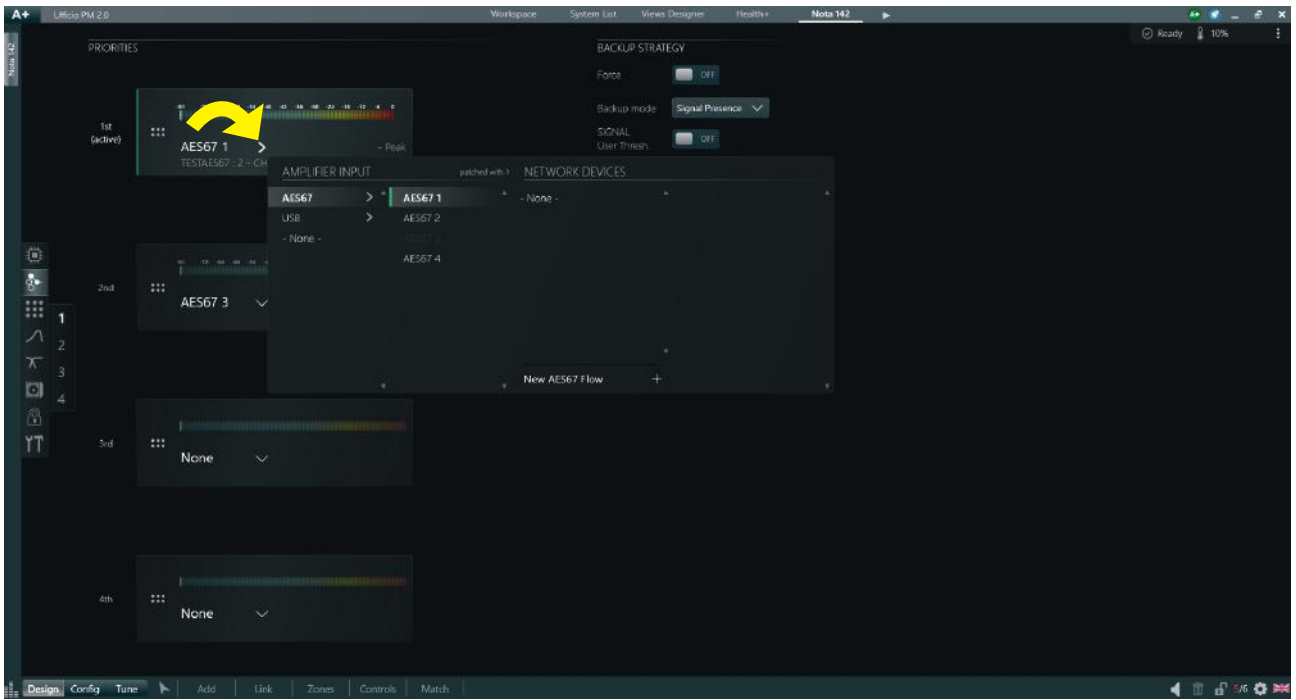

Figure 17- Input patching in Source Selection section of ArmoniaPlus

After completing the input patching process, Nota can begin operating with its default configuration (diagonal matrix, no delay, and no DSP). To modify the matrix, input or output settings, access the amplifier's internal settings:

1. In **Workspace** view, select the **Cursor** tool.
2. Double-click the amplifier to open its **Device details** page.
3. In the left-hand panel, select the appropriate section to adjust parameters as desired.

At this point, Nota is fully ready for operation.

MAINTENANCE

This section provides guidance on performing maintenance tasks for the Nota amplifier. In the event of a configuration issue or the need to restore factory-default settings, refer to the Operation section of this manual for detailed instructions on executing the reset procedure.

Updating firmware

Firmware updates for the Nota amplifier can be conducted using ArmoníaPlus software or Powersoft Cloud. During the firmware update sequence the LED turns on steady white.

Update via ArmoníaPlus software

In the **Match** section of ArmoníaPlus, any devices with outdated firmware are indicated in red. Opening the **System List** view displays the outdated firmware version, also shown in red, beside each device. Select the device in the list you want to update. Clicking **Update** initiates the firmware upgrade process.

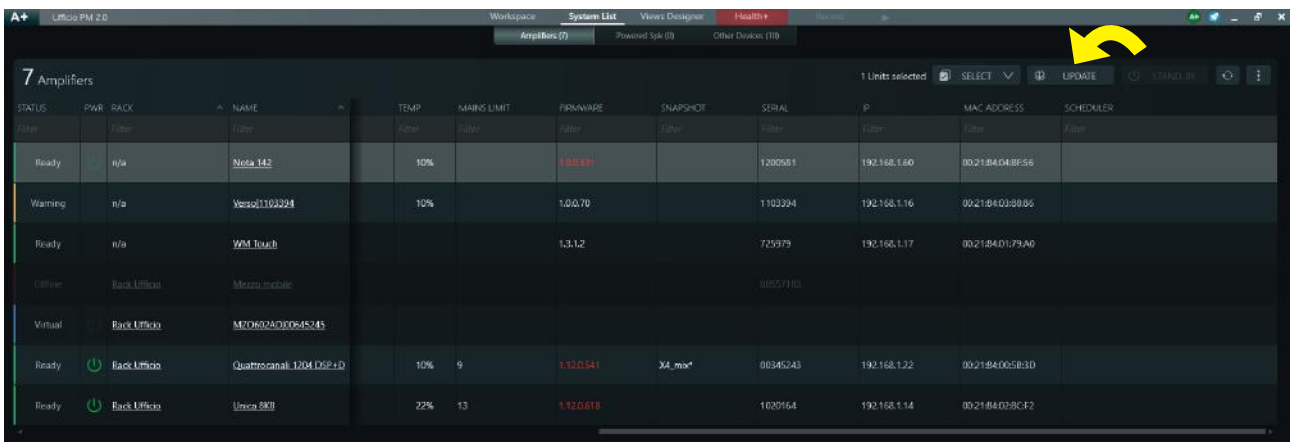

Figure 18 – Updating firmware from System List on ArmoníaPlus

Update via Powersoft Cloud

Amplifiers can also receive firmware updates through the Powersoft Cloud. When one or more amplifiers have outdated firmware, a suggestion appears in the suggestions box of myUniverso Dashboard, with a link to proceed (1). The link grants direct access to the Devices page, where outdated firmware can be updated.

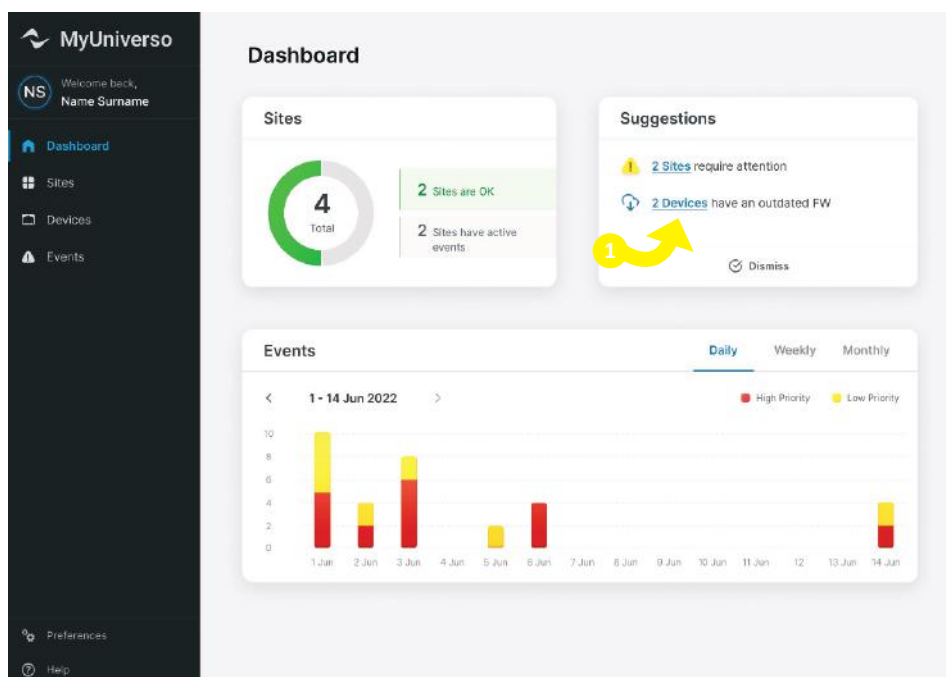

Figure 19 – Nota FW update via Cloud. Outdated FW notification

To update the outdated amplifiers, the operator selects the desired devices from their check box **(2)** and then clicks **Update (3)**. A link in the devices panel navigates to a page where filters can be applied to list all the outdated amplifiers.

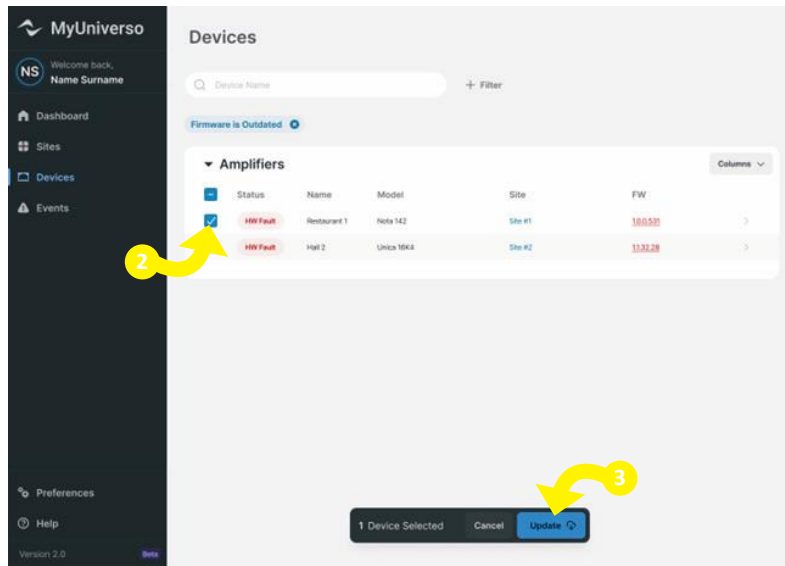

Figure 20 – Nota FW update via Cloud. Selecting amplifiers and updating FW

Once the update completes, the device will be running the latest firmware version.

APPENDIX

Third-Party Plugins (Q-SYS)

Third-party plugins are available for Nota amplifier, to easily integrate Nota in larger systems with third-party processors.

Q-SYS

Nota amplifier can be incorporated into a Q-SYS system for streamlined remote control and monitoring. The Q-SYS plugin is developed and maintained by Powersoft, ensuring seamless compatibility and reliable performance.

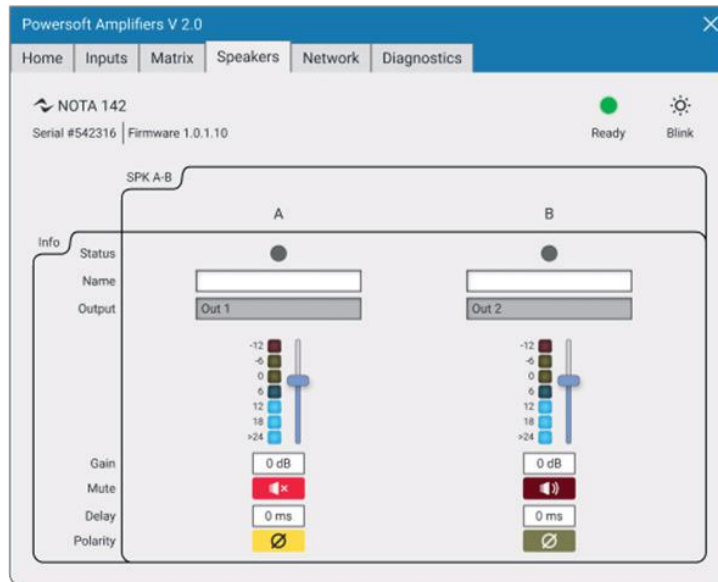

Figure 21- Q-SYS plugin interface for Nota amplifier

UI - LED behavior and operation

This section contains the LED status table that consolidates the information discussed for the Nota amplifier. It follows a simple layout, with each row describing a distinct LED color with its lighting (steady or blinking), the condition/operation that triggers it, and a brief explanation of the resulting behavior.







LED Color		Lighting	Condition/Operation	Description
	OFF	-	<ul style="list-style-type: none"> Amplifier unpowered Certain button-hold durations that cancel an operation 	Indicates amplifier is not powered or that a pushbutton action can be aborted.
	Green	Steady	Amplifier is on and in normal operation	The amplifier is powered and functioning correctly without any alarms or ongoing procedures.
	Red	Blinking	Alarm Condition	A fault or error has been detected; the amplifier may require attention or troubleshooting.
	Yellow	Steady	Limiting in one or more channels	Amplifier is actively limiting output on one or more channels to prevent damage or distortion.
		Blinking	Warning	The system has detected a non-critical condition; user intervention may be required if it persists.
	White	Steady	<ul style="list-style-type: none"> Factory Reset ready Firmware update in progress 	Appears after holding the button for 3 seconds at power-up or during a firmware update procedure.
		Blinking	<ul style="list-style-type: none"> Factory Reset in Progress Call / Pairing Operations 	Continues blinking while the device is resetting or when called/pinged from software.
	Purple	Steady	Autosetup Ready	The Autosetup procedure can be initiated.
		Blinking	<ul style="list-style-type: none"> Autosetup in progress Firmware Beta Version 	The amplifier is performing the Autosetup procedure or if blinking with a special pattern indicates a Beta Firmware is running.
	Cyan	Steady	Network Reset Ready	Appears after holding the button for 7 seconds; network reset procedure can be initiated.
		Blinking	Network Reset in Progress	Default network settings are being restored.

Table 4 – LED Table



POWERSOFT S.P.A.
Via E. Conti, 5 - Scandicci (FI) 50018 - Italy
support@powersoft.com
+39 055 73 50 230
+39 055 73 56 235

POWERSOFT.COM